

# SCHEFFKNECHT



## MOBILBAUKRAN

MK 88 PLUS

TECHNISCHE DATEN

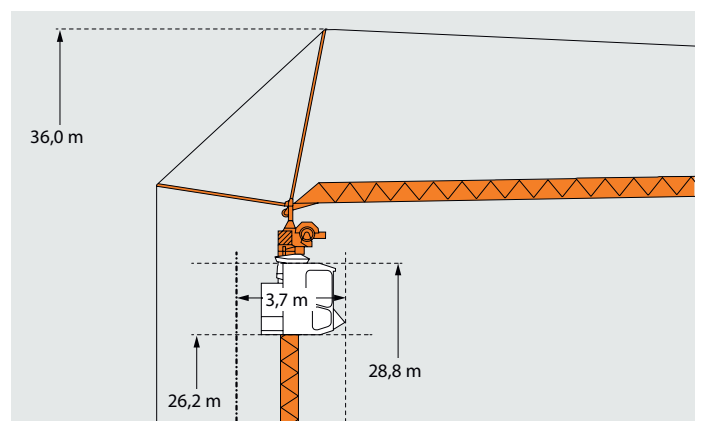
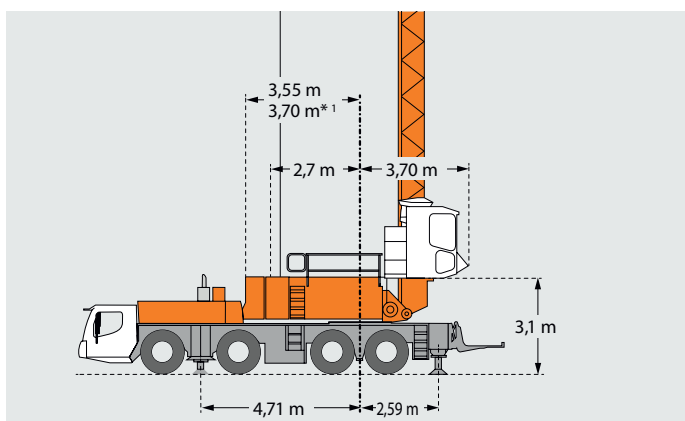
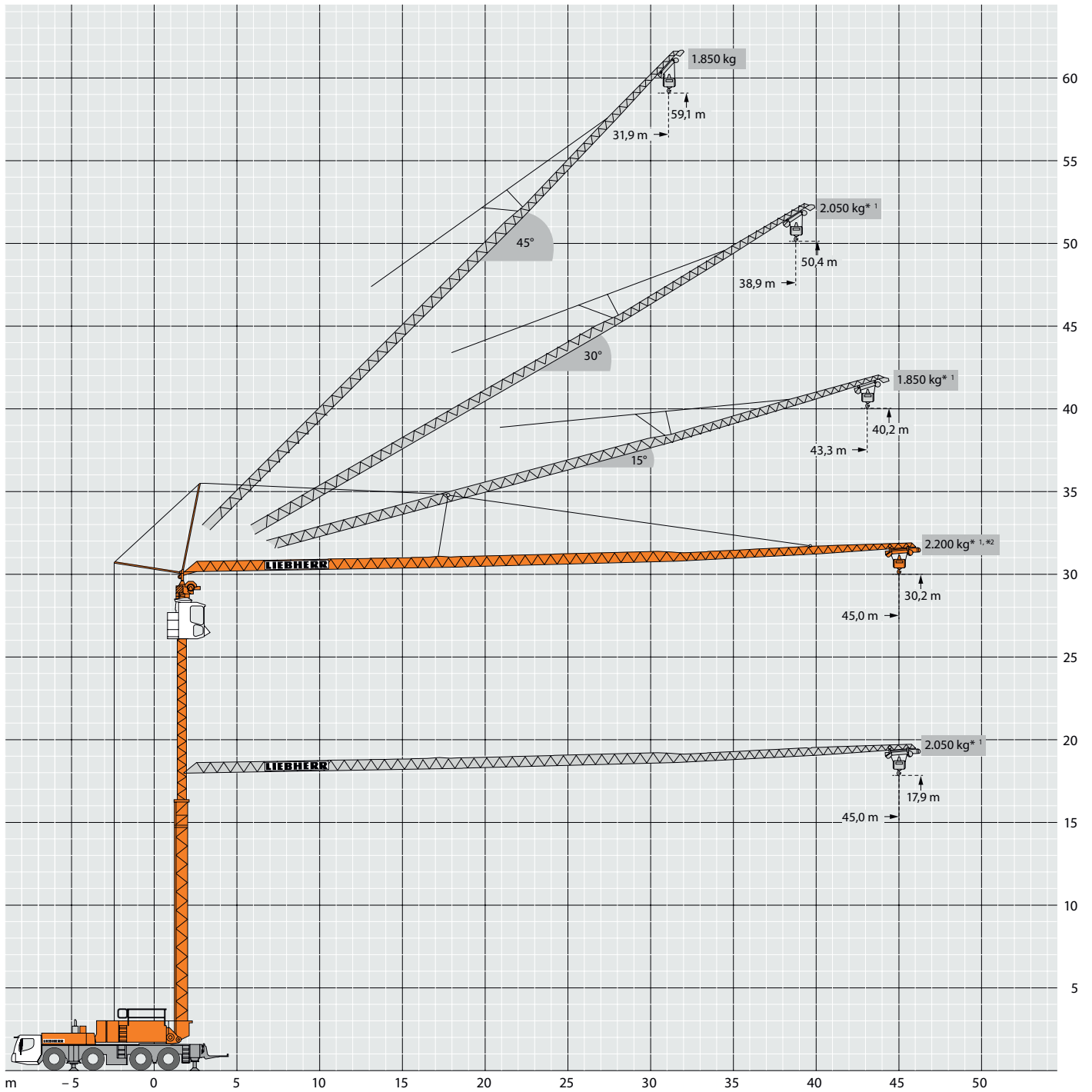

## MK 88 Aufstellvorgang

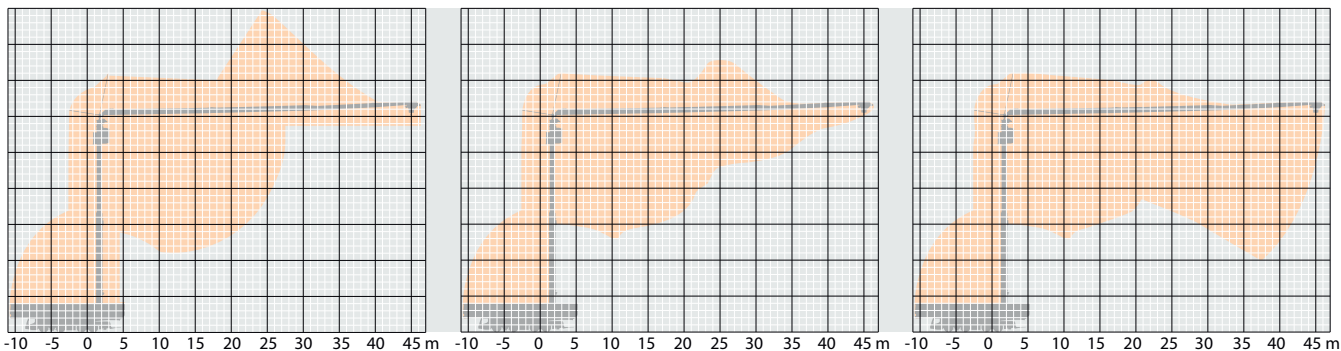

## Transport

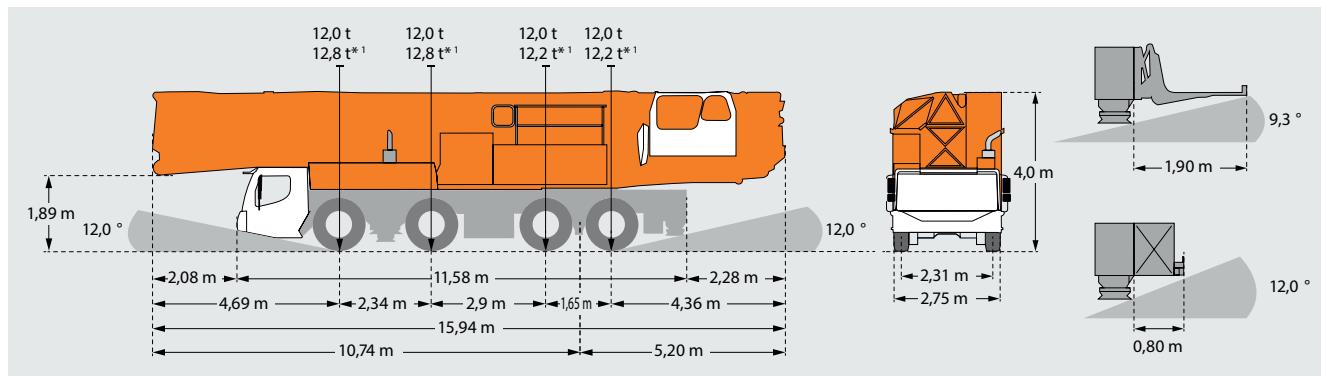

## Draufsicht

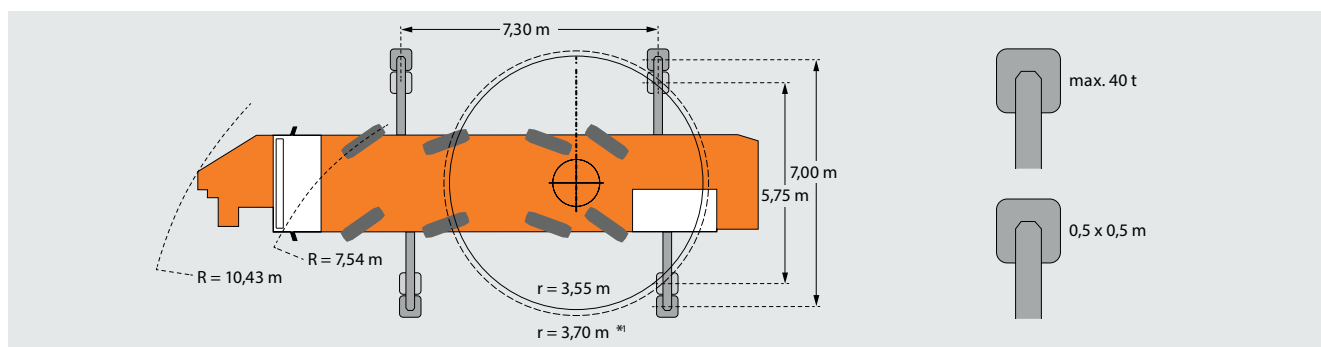



## MK 88, \* 1 mit Zusatzballast



|                |         |    |            | m    |      |      |      |      |      |      |      |      |      |      |      |      |      |         |      |         |      |      |      |  |  |  |
|----------------|---------|----|------------|------|------|------|------|------|------|------|------|------|------|------|------|------|------|---------|------|---------|------|------|------|--|--|--|
| $\alpha^\circ$ | m       | kg | 10,0       | 12,0 | 14,0 | 16,0 | 18,0 | 20,0 | 22,0 | 24,0 | 26,0 | 28,0 | 30,0 | 32,0 | 34,0 | 36,0 | 38,0 | 40,0    | 42,0 | 44,0    | 45,0 |      |      |  |  |  |
| 0°             | 45,0    |    | 3,3 - 12,0 | 8000 | 8000 | 8000 | 6900 | 6070 | 5410 | 4870 | 4420 | 4050 | 3730 | 3450 | 3210 | 2990 | 2800 | 2630    | 2480 | 2340    | 2220 | 2100 | 2050 |  |  |  |
|                |         |    | 3,3 - 11,0 | 8000 | 8000 | 7370 | 6360 | 5580 | 4960 | 4460 | 4050 | 3700 | 3400 | 3140 | 2920 | 2720 | 2540 | 2390    | 2250 | 2120    | 2000 | 1900 | 1850 |  |  |  |
|                | Plus* 2 |    | 3,3 - 13,0 | 8000 | 8000 | 7490 | 6600 | 5900 | 5320 | 4840 | 4440 | 4090 | 3790 | 3530 | 3300 | 3090 | 2920 | 2760    | 2600 | 2440    | 2280 | 2200 |      |  |  |  |
| 15°            | 43,3    |    | 3,2 - 40,0 | 1850 | 1850 |      |      |      |      |      |      |      |      |      |      |      |      |         |      | 1700* 3 |      |      |      |  |  |  |
|                |         |    | 3,2 - 35,0 | 1850 | 1850 |      |      |      |      |      |      |      |      |      |      |      |      | 1400* 3 |      |         |      |      |      |  |  |  |
| 30°            | 38,9    |    | 3,0 - 11,0 | 6000 | 6000 | 5650 | 5050 | 4560 | 4150 | 3810 | 3510 | 3250 | 3030 | 2830 | 2650 | 2490 | 2350 | 2220    | 2050 |         |      |      |      |  |  |  |
|                |         |    | 3,0 - 9,0  | 6000 | 5620 | 4970 | 4450 | 4020 | 3660 | 3360 | 3100 | 2870 | 2670 | 2490 | 2340 | 2200 | 2070 | 1950    | 1800 |         |      |      |      |  |  |  |
| 45°            | 31,9    |    | 2,7 - 31,9 | 1850 | 1850 |      |      |      |      |      |      |      |      |      |      |      |      |         |      |         |      |      |      |  |  |  |
|                |         |    | 2,7 - 31,9 | 1850 | 1850 |      |      |      |      |      |      |      |      |      |      |      |      |         |      |         |      |      |      |  |  |  |

kg



|                |      |    |            | m    |      |      |      |      |      |         |      |      |      |      |         |      |         |      |      |      |      |      |      |
|----------------|------|----|------------|------|------|------|------|------|------|---------|------|------|------|------|---------|------|---------|------|------|------|------|------|------|
| $\alpha^\circ$ | m    | kg | 10,0       | 12,0 | 14,0 | 16,0 | 18,0 | 20,0 | 22,0 | 24,0    | 26,0 | 28,0 | 30,0 | 32,0 | 34,0    | 36,0 | 38,0    | 40,0 | 42,0 | 44,0 | 45,0 |      |      |
| 0°             | 45,0 |    | 3,3 - 10,5 | 8000 | 8000 | 6930 | 5870 | 5080 | 4470 | 3980    | 3580 | 3250 | 2970 | 2730 | 2520    | 2340 | 2180    | 2030 | 1910 | 1790 | 1690 | 1590 | 1550 |
|                |      |    | 3,3 - 9,5  | 8000 | 7590 | 6310 | 5380 | 4680 | 4130 | 3690    | 3320 | 3020 | 2760 | 2540 | 2350    | 2180 | 2030    | 1900 | 1780 | 1680 | 1580 | 1490 | 1450 |
| 15°            | 43,3 |    | 3,2 - 34,0 | 1850 | 1850 |      |      |      |      |         |      |      |      |      |         |      | 1450* 3 |      |      |      |      |      |      |
|                |      |    | 3,2 - 29,0 | 1850 | 1850 |      |      |      |      |         |      |      |      |      | 1150* 3 |      |         |      |      |      |      |      |      |
| 30°            | 38,9 |    | 3,0 - 11,0 | 6000 | 6000 | 5580 | 4880 | 4320 | 3880 | 3510    | 3200 | 2930 | 2700 | 2500 | 2330    | 2180 | 2040    | 1910 | 1750 |      |      |      |      |
|                |      |    | 3,0 - 9,0  | 6000 | 5480 | 4650 | 4030 | 3540 | 3150 | 2830    | 2570 | 2340 | 2150 | 1980 | 1830    | 1700 | 1590    | 1490 | 1350 |      |      |      |      |
| 45°            | 31,9 |    | 2,7 - 31,9 | 1850 | 1850 |      |      |      |      |         |      |      |      |      |         |      |         |      |      |      |      |      |      |
|                |      |    | 2,7 - 24,0 | 1850 | 1850 |      |      |      |      | 1350* 3 |      |      |      |      |         |      |         |      |      |      |      |      |      |

kg